



The Journal of Sustainable Development Law and Policy



ISSN: 2467-8406 (Print) 2467-8392 (Online) Journal homepage: <https://www.ajol.info/index.php/jsdlp>

Study of the Efficiency of the Solar-Wind Hybrid Energy Generating System: Its Policy Assessment and Operations in Nigeria

Imhade P. Okokpujie, Lagouge K. Tartibu, Olusola J. Olujobi, Stella I. Monye, Ngozi S. Monye and Elizabeta S. Olarinde

To cite this article: Imhade P. Okokpujie, Lagouge K. Tartibu, Olusola J. Olujobi, Stella I. Monye, Ngozi S. Monye and Elizabeta S. Olarinde (2024). Study of the Efficiency of the Solar-Wind Hybrid Energy Generating System: Its Policy Assessment and Operations in Nigeria. *The Journal of Sustainable Development, Law and Policy*. Vol. 15:3. 1-31. DOI: 10.4314/jsdlp.v15i3.1

To link this article: DOI:10.4314/jsdlp.v15i3.1



Received: 1 August, 2024;

Final Version Received: 16 September, 2024;

Published online: September, 2024

Full Terms & Conditions of access and use can be found at
<https://www.ajol.info/index.php/jsdlp>

STUDY OF THE EFFICIENCY OF THE SOLAR-WIND HYBRID ENERGY GENERATING SYSTEM: ITS POLICY ASSESSMENT AND OPERATIONS IN NIGERIA

Imhade P. Okokpujie *, **, Lagouge K. Tartibu**, Olusola J. Olujobi***,
Stella I. Monye*, Ngozi S. Monye****, Elizabeta S. Olarinde*****

ABSTRACT

The Nigerian government has promoted industrial development based on the area of policy implementation. The development of policy and the use of renewable energy in terms of solar and wind energy generation is very significant because of the role of generating energy from green sources in reducing environmental pollution. The aim is to study the efficiency of the solar-wind hybrid energy generating system and the policy assessment of its operations in Nigeria. This research is conducted via a rigorous literature review that cuts across the solar-wind hybrid renewable energy system, grid integration, and energy storage for solar and windmill systems. An alternative analysis is needed to develop energy sources from solar and Wind sources and to provide a strong policy for utilisation. After identifying the challenges, the study further discusses the challenges and future trends of solar-wind hybrid energy generating systems. Furthermore, to propose a solution, the study examined using the Benchmarking process for sustainable policy development for hybrid power generations via wind and solar. From the findings, the northern section has considerable potential, with a daily horizontal irradiation of 7kWh/m², making it suitable for large-scale solar photovoltaic (PV). The wind speed varies accordingly, but it has a high wind speed of close to 9.5 m/s, which is also viable for energy generation. Therefore, this study will recommend that the Nigerian government relate with other manufacturing industries that are stakeholders in the energy sector to build a sustainable energy generation farm made of solar and wind energy in Northern Nigeria. These results will increase the development and growth of Nigeria's economy and improve the lives of the citizens.

Keywords: Benchmarking Process; Renewable Energy; Solar-Wind Hybrid; Policy Development.

1. INTRODUCTION

The integration of renewable energy has gained much attention because it requires no fuel and is readily available, clean, and simple to install. Amidst the diverse array of sustainable energy options, photovoltaic (PV) and wind turbines (WT) have gained significant appeal because of their plentiful availability in the surrounding environment, technological advancements, and financial advantages. Due to the unfavourable nature of mutual intermittences, the hybrid combination of both distributed energy resources eliminates them, increasing system reliability. Hassan et al.¹ produced electricity with as little pollution as possible using clean, renewable energy. The study uses a hybrid system to overcome the limitations of renewable freestanding generating. The solar-wind hybrid energy generation system's working model ran smoothly. Considering its cost and effectiveness, all rural community members are advised to use the solar-wind hybrid system to generate electricity.²

Photovoltaic (PV) and wind energy systems are examples of sustainable energy systems commonly engineered to function independently or as part of a grid network. It can operate independently or in conjunction with the grid. Both on- and off-grid operations are possible with this converter, as depicted in Figure 1. This hybrid power system uses batteries to store energy

* Department of Mechanical and Mechatronics Engineering, Afe Babalola University, Ado Ekiti, 360001, Nigeria Email: ip.okokpujie@abuad.edu.ng

** Department of Mechanical and Industrial Engineering Technology, University of Johannesburg, Johannesburg, 2028, South Africa

*** Department of Public and International Law, Afe Babalola University, Ado Ekiti, Ekiti State, Nigeria.

**** Department of Information Communication Technology, University of Delta, Agbor, Delta State, Nigeria

***** Department of Private and Business Law, Afe Babalola University, Ado Ekiti 360101, Ekiti State, Nigeria.

¹ Hassan, Q., Abdulateef, A. M., Hafedh, S. A., Al-Samari, A., Abdulateef, J., Sameen, A. Z., ... & Jaszczur, M. (2023). Renewable energy-to-green hydrogen: A review of main resources routes, processes and evaluation. *International Journal of Hydrogen Energy*. <https://doi.org/10.1016/j.ijhydene.2023.01.175>.

² Hassan, Q., Hsu, C. Y., Mounich, K., Algburi, S., Jaszczur, M., Telba, A. A., ... & Barakat, M. (2024). Enhancing smart grid integrated renewable distributed generation capacities: Implications for sustainable energy transformation. *Sustainable Energy Technologies and Assessments*, 66, 103793. <https://doi.org/10.1016/j.seta.2024.103793>

efficiently and meet its necessary energy requirements. Whether photovoltaic, wind, and battery systems are connected to the grid or not, the control unit is made to manage energy and supply batteries, the grid, and loads with energy efficiency. This control unit, therefore, improves the system's efficiency.³

The world is becoming increasingly concerned about environmental degradation, which is mainly brought on by traditional fossil fuel-based power generation. This study investigates the viability of producing electricity with a hybrid power system (HPS) based on renewable energy sources (RESs). The complementarity between solar and wind energy is suggested to stabilise the combined power output when integrating solar and Wind energy into a hybrid power system (HPS). In particular, it minimises the standard deviation of HPS power output to ascertain the ideal shares of solar and Wind energies in power generation. It assesses the complementarity between solar and wind using Pearson's correlation coefficient. Pakistan is a case study to evaluate the suggested framework because independent solar or wind power systems have enough potential for solar-wind synergy. The optimal site for implementing solar-wind hybrid power systems is determined by optimising the benefits of their complementarity.⁴

³ Jadhav, R. S., & Patil, S. B. (2020, January). Design and implementation of PV-wind battery hybrid system for off-grid and on-grid. In 2020 Fourth International Conference on Inventive Systems and Control (ICISC) (pp. 612-618). IEEE. <https://doi.org/10.1109/ICISC47916.2020.9171150>

⁴ Wang, S., Zafar, M. W., Vasbieva, D. G., & Yurtkuran, S. (2024). Economic growth, nuclear energy, renewable energy, and environmental quality: Investigating the environmental Kuznets curve and load capacity curve hypothesis. *Gondwana Research*, 129, 490-504. <https://doi.org/10.1016/j.gr.2023.06.009>

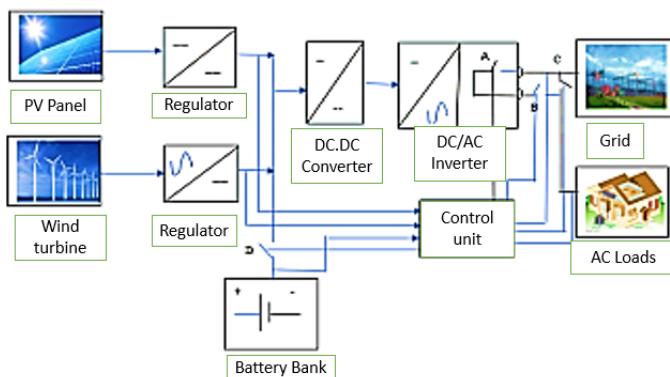

Figure 1: Block Illustration of PV-Wind Battery-Based ON and OFF Grid Architecture⁵

The increasing depletion of non-renewable energy sources is primarily blamed for the global trend toward using environmentally friendly or renewable energy.⁶ There are still 1.4 billion people without access to an essential electricity supply worldwide, and renewable energy is widely regarded as one of the most practical ways to address this problem.

Generally speaking, biomass, geothermal, hydro, solar, or wind energy sources provide renewable energy. Primary cause for concern is reliability, defined as the power quality of the energy supplied. Because renewable energy sources like solar and wind are unpredictable, green power generators must be more efficient than conventional ones. Before increasing the use of energy from renewable sources, these problems need to be resolved. This paper aims to study the efficiency of the solar-wind hybrid energy generating system and the policy assessment of its operations in Nigeria. Once created, green energy will be delivered to end customers via freestanding distributed generators linked to the primary grid.⁷ However, due to the expensive

⁵ Ibid

⁶ Wang, S., Zafar, M. W., Vasbieva, D. G., & Yurtkuran, S. (2024). Economic growth, nuclear energy, renewable energy, and environmental quality: Investigating the environmental Kuznets curve and load capacity curve hypothesis. *Gondwana Research*, 129, 490-504. <https://doi.org/10.1016/j.gr.2023.06.009>

⁷ ALAhmad, A. K., Verayiah, R., & Shareef, H. (2024). Long-term optimal planning for renewable-based distributed generators and battery energy storage systems

investment in producing renewable energy, the penetration level of such an energy market remains relatively low. The use of renewable energy is still limited to urban areas due to funding and development concentrations.⁸ Additionally, remote renewable energy technologies have been used in rural areas of several Latin American, African, and South and Southeast Asian countries.⁹ These technologies include biomass gasification, micro-hydroelectric, solar photovoltaic (PV), and wind-hybrid systems. Off-grid electrification is a valuable technique, particularly when extending the grid is not environmentally or financially feasible. However, now that these renewable energy sources have been established, the primary cause for concern is reliability, defined as the power quality of the energy supplied. Because renewable energy sources like solar and wind are unpredictable, green power generators must be more efficient than conventional ones. Before increasing the use of energy from renewable sources, these problems need to be resolved. This paper aims to study the efficiency of the solar-wind hybrid energy generating system and the policy assessment of its operations in Nigeria.

2. SOLAR-WIND HYBRID RENEWABLE ENERGY SYSTEM

A wind turbine is a structure that completes the conversion of wind energy into power. These days, power is becoming increasingly scarce. Thus, the renewable resources will be used to generate electricity in the future. In fact, between 5% and 10% of power generated nowadays comes from solar and Wind energy. Even though machines computerise all of a person's tasks, power generation is still inadequate. Given the facts above, a hybrid wind and solar energy system was created to produce electricity. The model combines solar panels and a horizontal-axis wind turbine. The solar panel tiles are installed alongside the turbine blades, and the wind turbine blades are made

toward enhancement of green energy penetration. *Journal of Energy Storage*, 90, 111868. <https://doi.org/10.1016/j.est.2024.111868>

⁸ Bildirici, M., & Çoban Kayıkçı, F. (2024). Energy consumption, energy intensity, economic growth, FDI, urbanisation, PM2. 5 concentrations nexus. *Environment, Development and Sustainability*, 26(2), 5047-5065. <https://doi.org/10.1007/s10668-023-02923-9>.

⁹ Zhang, H., Jing, Z., Ali, S., Asghar, M., & Kong, Y. (2024). Renewable energy and natural resource protection: Unveiling the nexus in developing economies. *Journal of Environmental Management*, 349, 119546. <https://doi.org/10.1016/j.jenvman.2023.119546>.

of PVC pipes. Malik et al.¹⁰ the project outline the modelling of two newly developed renewable energy-based electrical systems: Wind and photovoltaic. An inverter was connected to the combined power output of the two sources via a charge controller. Ultimately, the residential load received this power. The prototype evaluates a combined solar and wind system for necessities like fans and lighting. Additionally, wind turbines can run at lower wind speeds, which boosts the system's overall efficiency. A wind turbine model was developed and reviewed to meet the houses' energy needs. This model was tested with solar panels to evaluate the aggregate plan's effectiveness and power yield. The suggested system outperformed the conventional system in many ways, as demonstrated by comparing the two systems. During the manufacturing process, the wind turbine's performance was enhanced. When the turbine is used in conjunction with solar panels, the execution is significantly improved.

By integrating wind and solar energy sources optimally, the intermittent nature of these resources can be minimised, increasing the overall system's operational reliability and economy.¹¹ Soudagar et al.¹² This study discusses the benefits and drawbacks of hybrid wind and solar energy integration systems. In weak grids, the effects of harmonics and oscillations in voltage and frequency are magnified, impacting both standalone and grid-connected systems. This could be resolved by ensuring hybrid systems are correctly engineered, furnished with state-of-the-art fast reaction control features, and optimised. In addition to examining prospective future developments, this review provides an overview of recent advancements in PV-solar and wind-based hybrid energy systems. Moreover, an overview of the main research works on control, power electronics topologies, and compactness optimal design considerations is given in this research. This review assists scholars,

¹⁰ Malik, P., Awasthi, M., & Sinha, S. (2021). Techno-economic and environmental analysis of biomass-based hybrid energy systems: A case study of a Western Himalayan state in India. *Sustainable Energy Technologies and Assessments*, 45, 101189. <https://doi.org/10.1016/j.seta.2021.101189>

¹¹ Liang, H., & Pirouzi, S. (2024). Energy management system based on economic Flexi-reliable operation for the smart distribution network including integrated energy system of hydrogen storage and renewable sources. *Energy*, 130745. <https://doi.org/10.1016/j.energy.2024.130745>.

¹² Soudagar, M. E. M., Ramesh, S., Khan, T. Y., Almakayeel, N., Ramesh, R., Ghazali, N. N. N., ... & Shelare, S. (2024). An overview of the existing and future state-of-the-art advancement of hybrid energy systems based on PV-solar and Wind. *International Journal of Low-Carbon Technologies*, 19, 207-216. <https://doi.org/10.1093/ijlct/ctad123>

decision-makers, and industry participants in comprehending, adjusting, and improving PV-solar-wind hybrid energy systems as the world's energy landscape moves toward sustainability and resilience.

Kapica et al.¹³ examined the two potential scenarios for climate change, the performance of solar, wind, and solar-wind hybrid systems in Europe using eight regional climate models. The energy drought concept has been used to assess the availability of resources. The total duration of droughts is computed using daily capacity factors for the reference period of 1970–2020 and the future period of 2048–2098, which considers sub-national regions throughout Europe. The selected climate models generally indicate a stronger agreement regarding the frequency of energy droughts in northern and southern Europe than in its central region. The study ensures safe and dependable power system operation in the current and future climates, and it is imperative to evaluate the possibility of droughts in renewable energy. Natarajan et al.¹⁴ studied the Time of Use (TOU) tariff in grid-connected household PV-wind power systems connected to battery storage units. They proposed using the Multitrial Vector-Based Differential Evolution Algorithm (MTDE) as an energy and cost management controller. MPPT algorithms include differential, incremental conductance, short circuit, and perturbation and observation (P&O) methods. Methods for climbing hills have the benefit of being straightforward to use. The nonlinearities in the characteristics are handled by the fuzzy logic-based MPPT, which does not require the system's mathematical model.

Due to its insensitivity to changes in circuit parameters, the fuzzy logic MPPT algorithm has fewer oscillations at the maximum power point during variations in temperature and insolation. Two optimisation strategies are proposed in the sequencing operation to increase the energy efficiency of a planned power system. TOU billing is a cost-indicative power pricing strategy that significantly reduces peak energy usage in the residential sector worldwide, mainly in industrialised countries. According to Kumar &

¹³ Kapica, J., Jurasz, J., Canales, F. A., Bloomfield, H., Guezgouz, M., De Felice, M., & Zbigniew, K. (2024). The potential impact of climate change on European renewable energy droughts. *Renewable and Sustainable Energy Reviews*, 189, 114011. <https://doi.org/10.1016/j.rser.2023.114011>

¹⁴ Natarajan, S., & Loganathan, A. K. (2024). Fuzzy logic inherited machine learning-based maximum power point trackers for cost-optimised grid-connected hybrid renewable systems. *Iranian Journal of Fuzzy Systems*, 21(1), 103-128. <https://doi.org/10.22111/IJFS.2023.44709.7874>.

Shivashankar¹⁵ a doubly fed induction generator (DFIG) is a slip ring or wound-rotor induction generator in which the rotor is connected to a variable frequency source. Improve the maximum power tracking efficiency of a grid-connected wind-powered Doubly Fed Induction Generator (DFIG) by combining it with a solar photovoltaic (PV) system and connecting it to the DC link of the HWSES's back-to-back converters. Stator Flux-Oriented control is used to operate the Grid Side Converter and Rotor Side Converter. The hybrid system, which includes a solar PV system, evaluates the performance and efficiency of the Tip Speed Ratio (TSR) and Optimal Torque (OT) MPPT algorithms at various wind speeds. The optimal torque MPPT algorithm produces better results than the TSR technique. The HWSES is simulated using a 2MW model, and its performance is analysed using the MATLAB/Simulink environment. The applied solutions profit from the ability to quickly and accurately track the HWSES's ideal power output. Furthermore, the systems provided excellent power flow regulation across the utility grid and the HWSES, resulting in rapid transient response and better stability.

Subrahmanyam et al.¹⁶ stated that some countries' energy projects have caused social division. As a result, global, local, geographic, national, and international governmental and legislative bodies are quite concerned about the environmental effects and risk factors that influence energy paradigms. Consequently, to lessen and limit the issues associated with environmental insecurity, the world needs to act quickly and effectively to protect the environment for a brighter future. It begins with a summary of energy-related issues and prospects, then compares and contrasts RES and non-RES. A thorough overview of several Sustainable Energy Sources (SES), including wind and solar, is given, along with relevant illustrations and statistical data on the global energy potential of each source. Rtemi et al.¹⁷ studied electricity loads, meteorological data sources, power component economics, and other factors considered when optimising power systems. The total net present cost

¹⁵ Kumar, G. A., & Shivashankar. (2022). Optimal power point tracking of solar and Wind energy in a hybrid wind-solar energy system. *International Journal of Energy and Environmental Engineering*, 13(1), 77-103. <https://doi.org/10.1007/s40095-021-00399-9>

¹⁶ Subrahmanyam, S., Khalife, D., & El-Chaarani, H. (2024). Towards Sustainable Future: Exploring Renewable Energy Solutions and Environmental Impacts. *Acta Innovations*, 51, 15-24. <https://doi.org/10.62441/ActaInnovations.51.3>

¹⁷ Rtemi, L. A., El-Osta, W., & Attaieq, A. (2023). Hybrid system modelling for renewable energy sources. *Journal of Solar Energy and Sustainable Development*, 12(1).

(NPC) must be minimised to choose a financially feasible power system. Additional considerations assessed to check technical capabilities included a renewable proportion, capacity constraints, cost of energy (COE), and excess electricity. Four scenarios of capacity deficit were investigated using sensitivity analyses of the most influential variables. The optimum alternative for the off-grid hybrid system is scenario four, where the capacity shortage is 5% of the annual electric load of 60,385.6 kWh, peaking at 43.45 kW. The lowest COE is 0.222 \$, while the NPC is 168,173 \$. The system comprises 72 Hoppecke batteries of 1500 Ah each, one 25 kW turbine, and a 20 kW PV system. The yearly percentage of solar energy was 22.9%, whereas the annual share of wind energy was 77%. The predicted oversupply of electricity was 58.3%.

Ismail et al.¹⁸ The highest electricity output from clean energy sources, such as solar irradiance and wind energy, was achieved by utilising an integrated solar and wind energy system consisting of two solar modules and horizontally moving wind blades. An energy storage system and a charge controller were also employed to improve total energy conversion efficiency. Based on the data, the proposed system was expected to yield roughly 207.4 kWh of annual output power, outperforming the solar modules and wind systems while working individually. Gajewski and Pieńkowski¹⁹ categorised and analysed hybrid renewable energy system architectures presented in this paper. The hybrid green power system under evaluation was designed as a multi-converter system that included a gearless wind turbine-driven permanent magnet synchronous generator, a solar array, and a battery energy system. The mathematical models for each complicated hybrid renewable energy system component were described. Maximum power point tracking algorithms were used to regulate the wind turbine by boosting the energy conversion efficiency, including a synchronous generator with a permanent magnet and a solar array. The performed simulations are crucial for suitable operation, part design, and management of energy in hybrid renewable energy technologies via solar and wind energy.

¹⁸ Ismail, F. B., Al-Muhsen, N. F., & Noruddin, N. I. (2020). Design and development of dual power generation solar and windmill generators. *International Journal of Electrical and Electronic Engineering & Telecommunications*, 9(6), 447-454. <https://doi.org/10.18178/ijeetc.9.6.447-454>

¹⁹ Gajewski, P., & Pieńkowski, K. (2021). Control of the hybrid renewable energy system with the wind turbine, photovoltaic panels and battery energy storage. *Energies*, 14(6), 1595. <https://doi.org/10.3390/en14061595>

Blaabjerg and Ionel²⁰ studied the principles of PV systems and wind turbines, which are then covered. Schematic diagrams showing the major parts and system topologies are also included, along with information on power electronics's fundamental and growing role as a catalyst for integrating renewable energy sources and developing future power systems and smart grids. Here are some recent instances of research and development, such as new tools and system installations for utility power plants, as well as applications for homes and businesses.

2.1 Grid Integration and Energy Storage for Solar and Windmill Systems

According to Awasthi et al.²¹ Energy storage systems, or ESSs, can supply or store excess or deficient energy with a high rate of responsiveness and efficiency. This helps to meet the demands of consumers, which can vary greatly and quickly within a single day. When there is no central grid, there are two main types of smart grid designs: DC microgrids and AC microgrids. Energy storage units improve the dependability of the power supply for consumer load demands when microgrids are equipped with renewable energy sources. Finding the most efficient way to draw energy from renewable sources like fuel cells, solar power, and wind during an islanding incident is challenging. Energy storage devices are necessary because power imbalances occasionally occur and fuel the need for energy when load demand exceeds power generation. A microgrid-connected load's power needs to be switched on quickly and dynamically, and this can be achieved by designing an energy storage unit accordingly. The burden on conventional generating units can be lessened in an AC microgrid by having local energy sources and the capacity to control voltage and frequency. Such a problem does not arise in DC microgrids; nevertheless, voltage handling is a problem that needs to be addressed. The integration of energy storage systems (ESS) with DC or AC microgrids, as well as associated energy management control algorithms.

²⁰ Blaabjerg, F., & Ionel, D. M. (2015). Renewable energy devices and systems—state-of-the-art technology, research and development, challenges and future trends. *Electric Power Components and Systems*, 43(12), 1319-1328. <https://doi.org/10.1080/15325008.2015.1062819>

²¹ Awasthi, A., Karthikeyan, V., Das, V., Rajasekar, S., & Singh, A. K. (2017). Energy storage systems in solar-wind hybrid renewable systems. *Smart Energy Grid Design for Island Countries: Challenges and Opportunities*, 189-222. https://doi.org/10.1007/978-3-319-50197-0_7

Erenoğlu et al.²² researched Microgrids (MGs), small-scale, low-voltage energy systems that have become more significant in today's power grid. The stochastic character of wind and solar energy (PV) sources was considered. The system's demand response (DR) program, which is based on direct load control (DLC), aims to reduce energy consumption while meeting operational and comfort limitations by using electronically controlled appliances (TCAs). Furthermore, the proposed structure incorporates a common energy storage system (ESS) with forward power flow capability, and electric vehicles (EVs) are exploited as an extra flexibility load in grid-to-vehicle (G2V) mode. Various case studies with a range of scenarios are carried out to attest to the efficacy of the suggested optimisation algorithm. Additionally, from the standpoint of minimising loss and accounting for uncertainties, the performance is contrasted with a deterministic approach.

Abdelghany et al.²³ proposed the cost functions that consider the degradation of the battery and hydrogen devices to increase the lifespan of the hybrid ESSs. This paper attempts to develop a sophisticated model predictive control strategy about a grid-connected wind and solar microgrid incorporating a hydrogen energy storage system (ESS), a battery energy system, and communication with external consumers like battery/fuel cell electric vehicles. Controlling the energy production of the integrated system in both its electric and hydrogen forms is necessary. The hybrid-ESSs' economic and operational costs, the system's physical and dynamic limitations, and degradation problems make up the suggested approach. A mixed-logic dynamic framework is needed to model the hybrid ESSs' operating modes and switch switches between them. Utilising solar and Wind generation profiles from solar panels and wind farms in Abu Dhabi, United Arab Emirates, numerical simulations are used to assess the efficacy of the controller.

²² Erenoğlu, A. K., Şengör, İ., Erdinç, O., Taşçıkaraoğlu, A., & Catalão, J. P. (2022). Optimal energy management system for microgrids considering energy storage, demand response and renewable power generation. *International Journal of Electrical Power & Energy Systems*, 136, 107714. <https://doi.org/10.1016/j.ijepes.2021.107714>

²³ Abdelghany, M. B., Al-Durra, A., & Gao, F. (2023). A coordinated optimal operation of a grid-connected wind-solar microgrid incorporating hybrid energy storage management systems. *IEEE Transactions on Sustainable Energy*. <https://doi.org/10.1109/TSTE.2023.3263540>

Abdelsattar et al.²⁴ presented the introduction of the African Vultures Optimization Algorithm (AVOA) for the practical design of a grid-tied hybrid renewable energy (HRE) system that combines photovoltaic (PV) panels, wind turbines, and batteries for energy storage, as shown in Figure 2. The African Vultures Optimization Algorithm is a novel metaheuristic algorithm inspired by nature, developed by mimicking the foraging behaviours and natural behaviours of African vultures. For evaluation, the outcomes of the AVOA method are contrasted with those of the particle swarm optimisation (PSO) algorithm. The simulation results confirm that the AVOA is better than the PSO and demonstrate its potential to produce encouraging outcomes, as presented in Figure 3.

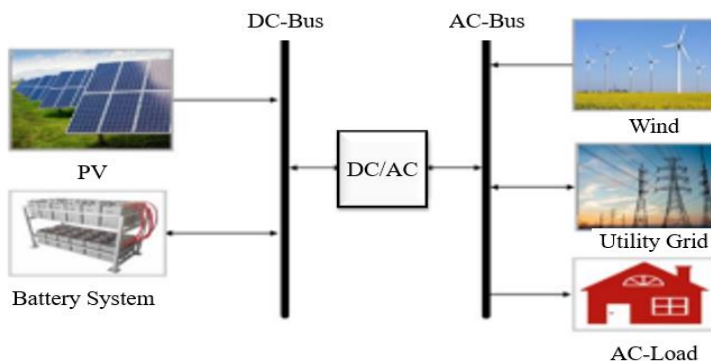

Figure 2: The Single line diagram of the grid-tied proposed HRE system²⁵

²⁴ Abdelsattar, M., Mesalam, A., Fawzi, A., & Hamdan, I. (2024). Optimising grid-dependent hybrid renewable energy system with the African vultures optimisation algorithm. *SVU-International Journal of Engineering Sciences and Applications*, 5(1), 89-98. <https://doi.org/10.21608/svusrc.2023.240888.1153>

²⁵ Ibid

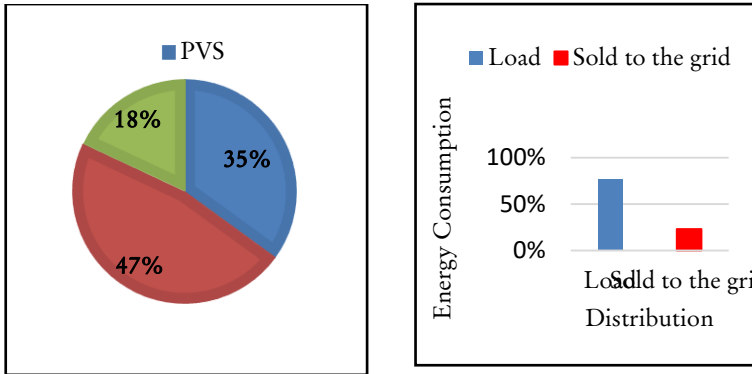

Figure 3: The Overview of AVOA results for annual energy production and consumption percentages²⁶

Farah and Andresen²⁷ examined the fact that new energy storage technologies must be improved to compete with lithium-ion batteries and lower energy costs. The nonlinearity of the energy system model makes it difficult to identify and optimise the most beneficial improvement path for these technologies when considering parameters as independent variables. An innovative investment-based optimisation technique is suggested as a solution to this problem. The process considers diminishing returns on investment by linearly optimising the hybrid renewable energy system and then optimising subsequent investments. The energy storage and discharge capacity costs rank second and third, respectively, while charge efficiency and capacity cost rank lowest. By helping developers allocate resources, the study offers comprehensive improvement pathways for each technology under various operating conditions. Sharma et al.²⁸ proposed that the research aims to generate electricity using the current solar and Wind resources presented. Nevertheless, because of the decrease in the limit deficit from 22.3% to 3.1%, a further 1 kW solar PV system might be added to the existing setup. Based

²⁶ Ibid

²⁷ Farah, S., & Andresen, G. B. (2024). Investment-based optimisation of energy storage design parameters in a grid-connected hybrid renewable energy system. *Applied Energy*, 355, 122384. <https://doi.org/10.1016/j.apenergy.2023.122384>

²⁸ Sharma, P. K., Kumar, D. A., William, P., Obulesu, D., Pandian, P. M., Khan, T. K., & Manikandan, G. (2023). Energy storage system based on hybrid wind and photovoltaic technologies. *Measurement: Sensors*, 30, 100915.

on the results, hybrid solar-wind energy systems can effectively use renewable energy sources for distributed applications.

Yousif et al.²⁹ examined potential designs for the large-scale electric grid system (26 GW) that were investigated, combining renewable energy sources (wind turbines, solar photovoltaics) with energy storage devices (electrolytic storage, fuel cell, battery pack). These configurations are chosen for two primary reasons. First, we analyse several types of renewable resources placed in different places with minor fluctuations and comparatively small energy storage devices. According to Patanik et al.³⁰ Artificial Rabbit Optimization (ARO) is a new bioinspired algorithm designed to solve the complex problem of nonlinear optimisation by taking inspiration from the survival strategies of rabbits. Foraging and hiding in unexpected places are two survival strategies that inspired the development of the ARO algorithm. Although there are many benefits to these energy sources, like lower emissions and operating costs, their power output is unpredictable. Optimising the scheduling of BESS charging is crucial for a microgrid with multiple energy sources to accommodate varying energy expenses.

Muller et al.³¹ observed that reducing carbon emissions and improving local grid stability benefit from implementing renewable energy systems, especially in high-demand areas with frequent power outages. Utilising a mathematical expression for the coefficient of variation, the Geeth Effect is quantifiable. Supercapacitors, filters, and battery energy storage systems linked to the wind turbine generators' output stage are among the installation recommendations. Supercapacitors are the best option for wind turbines due to their constant charge and discharge cycles, which can harm battery energy infrastructure. While high values are undesirable, low values of the coefficient of variation are preferred.

²⁹ Yousif, M., Ai, Q., Wattoo, W. A., Jiang, Z., Hao, R., & Gao, Y. (2019). Least cost combinations of solar power, wind power, and energy storage system for powering the large-scale grid. *Journal of power sources*, 412, 710-716. <https://doi.org/10.1016/j.jpowsour.2018.11.084>

³⁰ Patanik, S., Guru, N., Kasturi, K., & Nayak, M. R. (2023). Solar Photovoltaic and Wind Turbine Generation based Microgrid Management Architecture Considering Battery Energy Storage Degradation and Time of Use Tariff. *Journal of Solar Energy Research*, 8(2), 1459-1470. <https://doi.org/10.22059/jser.2023.356135.1276>

³¹ Muller, D. C., Selvanathan, S. P., Cüce, E., & Kumarasamy, S. (2023). Hybrid solar, wind, and energy storage system for a sustainable campus: A simulation study. <https://doi.org/10.2516/stet/2023008>

2.2 Study of Wind Turbine Design and Components for Sustainable Energy Generation

According to Okokpuije et al.³² Due to the difficulties posed by the little fluctuations in wind speed. Nonetheless, the main emphasis of this study is the implementation of MCDM to select a suitable material for developing a horizontal wind turbine blade. This study employed a quantitative research design with multi-criteria decision-making using AHP and TOPSIS. The research considered the circumstances surrounding the questionnaire's design process of the material selection phase, utilised in the selection procedure from the 130 research questionnaires; sustainable energy and materials engineers were given specialists.

Rehman et al.³³ examined an approach used in MCDM to choose the optimal solution from a set of options called TOPSIS (technique for order preference by similarity to an ideal solution). To optimise the energy yield from a wind farm, choosing a turbine that best fits the topography and geography of the site is a critical decision that must be made. The optimal selection mechanism considers several competing criteria; an improvement in one criterion should not come at the expense of another or several criteria. The TOPSIS method proved successful in determining which turbines would work best at each location; according to the results, the results analysis are presented in Figure 4a and Figure 4b—moreover, the suggested methodology aided in pinpointing the commonalities in the turbine performance at the two locations. The robustness of the strategy was demonstrated by comparing the TOPSIS approach with other multi-criteria decision-making strategies.

³² Okokpuije, I. P., Okonkwo, U. C., Bolu, C. A., Ohunakin, O. S., Agboola, M. G., & Atayero, A. A. (2020). Implementation of multi-criteria decision method for selection of suitable material for development of horizontal wind turbine blade for sustainable energy generation. *Heliyon*, 6(1). <https://doi.org/10.1016/j.heliyon.2019.e03142>

³³ Rehman, S., Khan, S. A., & Alhems, L. M. (2020). Application of TOPSIS approach to multi-criteria selection of wind turbines for onshore sites. *Applied Sciences*, 10(21), 7595. <https://doi.org/10.3390/app10217595>

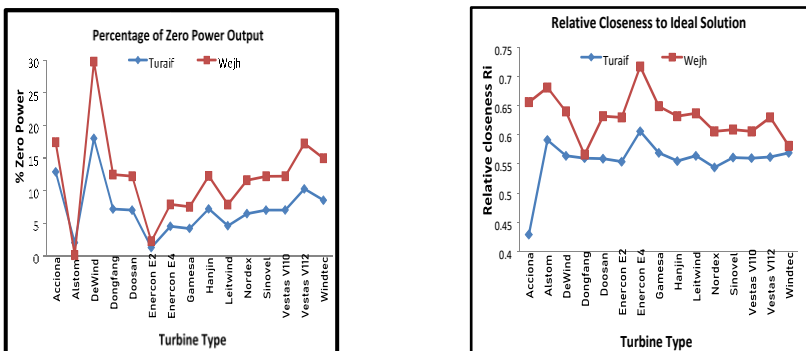

Figure 4: (a) Comparison of ZPO for different turbines for Turaiif and Wejh, and (b) The comparison of R_i for different turbines for Turaiif and Wejh³⁴

Thambidurai et al.³⁵ the study considered a chord-based Reynolds number range of $5.0e+4$ to $3.0e+6$, focusing on three distinct rotor blade designs: Helical, Tropo-skein, and Straight Bladed rotors, as shown in Figure 5.

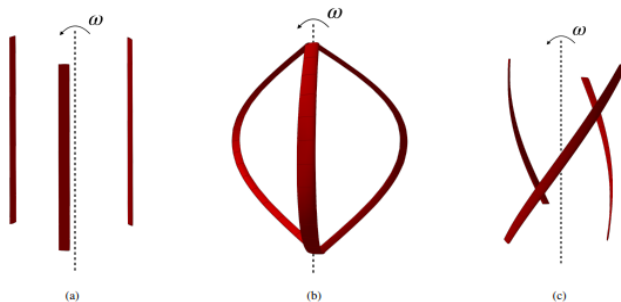

Figure 5: The VAWT Configurations: (a) Straight (b) Troposkein (c) Helical ($\varphi = 45^\circ$)³⁶

³⁴ Ibid

³⁵ Thambidurai Arasi, T. R., Shubham, S., & Ianakiev, A. (2024). Effect of Blade Shape on Aerodynamic and Aeroacoustic characteristics of Vertical Axis Wind Turbines using Mid-fidelity and high-fidelity methods. In AIAA SCITECH 2024 Forum (p. 1488). <https://doi.org/10.2514/6.2024-1488>

³⁶ Ibid

The study uses two different computational tools: 3DS Simulia Power FLOW 6-2020, a commercial program that uses the high-fidelity Lattice Boltzmann/Very Large Eddy Simulation (LB-VLES) method for computational fluid dynamics (CFD) calculations, and QBlade 2.0, an open-source C++ framework that uses the mid-fidelity unsteady Lifting Line Free Vortex Wake (LLFVW) method illustrated in Figure 6. The Ffowcs-Williams and Hawkins (FW-H) acoustic analogy is applied to compute the far-field noise. While maintaining a steady freestream velocity of 9 m/sec, the investigation uses VAWT configurations for various Tip Speed Ratios (TSRs).

Kumar and Selvaraj³⁷ utilised MATLAB Simulink to construct four wind turbine designs and analyse the accompanying output. MATLAB is a widely used graphical programming tool for designing, simulating, analysing input, and displaying the outcome. Defining the absolute environmental entrance velocity when calculating the wind turbine outlet velocity is necessary. As a result, a high-performance, one-of-a-kind design with an intake funnel with guide vanes, a natural fan, a straight flow section, an exit splitter with air holes, and an end flange is suggested. The diffuser enhances the wind turbine. The suggested ideas are investigated numerically with the aid of Ansys Fluent and MATLAB Simulink. These designs are optimised through Supervisory Control, Data Acquisition, and Random Search Optimisation techniques to assess wind velocity and compare performance.

³⁷ Kumar, R., Stallard, T., & Stansby, P. K. (2021). Large-scale offshore wind energy installation in northwest India: Assessment of wind resource using Weather Research and Forecasting and levelized cost of energy. *Wind Energy*, 24(2), 174-192. <https://doi.org/10.1002/we.2566>

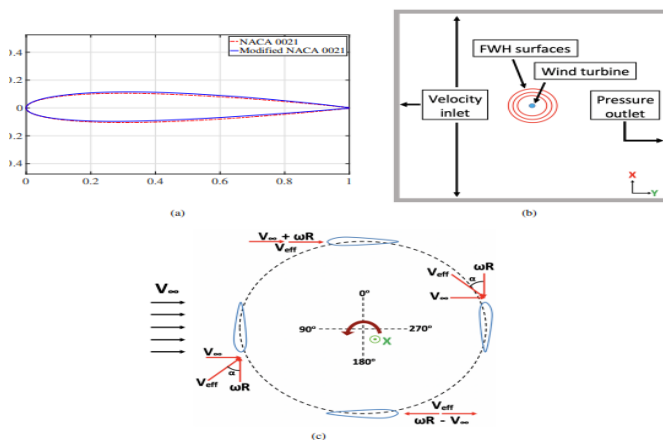

Figure 6: Numerical setup (a) Virtual curvature airfoil (blue) and genuine airfoil (red) for mid-fidelity modelling. (b) A schematic diagram of the modelling environment for high-fidelity LBM. (c) Location of Darrieus blades during a single motion, together with velocity graph in the blade base frame³⁸

Wang et al.³⁹ suggested to use a four-point support drivetrain arrangement with a gearbox that has one parallel stage and two planetary stages. Subsequently, the drivetrain's components are engineered according to prescribed design loads and requirements found in pertinent international standards. An iterative design process that reduces weight and volume yields an optimised drivetrain model. The multibody system approach is used to construct a high-fidelity numerical model. Next, a comparison is made between the produced drivetrain model and the DTU's simplified model, and the two models show good agreement. Furthermore, drivetrain resonance is assessed using the modal energy distribution and the Campbell diagrams. Comprehensive parameters for dynamic modelling and drivetrain design are included to aid in the drivetrain model's replication. Future research on multi-megawatt offshore wind turbines will have support and a foundation

³⁸ Ibid

³⁹ Wang, C., Zhang, H., & Ma, P. (2020). Wind power forecasting based on singular spectrum analysis and a new hybrid Laguerre neural network. *Applied Energy*, 259, 114139. <https://doi.org/10.1016/j.apenergy.2019.114139>

for benchmark studies thanks to the thorough modelling of the baseline drivetrain model.⁴⁰

Muhammed et al.⁴¹ observed that Nanocomposites are widely applicable in many fields. Because of their advantageous properties, glass fiber-reinforced epoxy matrix composites are strongly recommended for wind turbine blade manufacturing. The primary goal of this study is to determine the practicality of nanocomposites based on SiO₂ and Al₂O₃, primarily for usage in wind turbine blade applications. This paper aims to develop and thoroughly test nano SiO₂ and Al₂O₃ dispersed E-glass fiber/AW 106 epoxy composites. The number of nanoparticles was adjusted manually during layup to form composites. Tensile, fatigue, and hardness tests were conducted to determine the material's properties. According to test results, the nanocomposite containing 1% Al₂O₃ had ideal hardness and reasonably good tensile and fatigue strength. The microstructure of the composites was investigated using SEM and EDX analysis. Khalid et al.⁴² examined A wind turbine's structural lifetime, which is anticipated to be between 20 and 25 years, after which it must be deactivated at the end of its useful life (EOL). The global trend in recent years has been to use wind turbines to generate power, increasing the number of discarded wind turbine blades (WTBs) globally. Carbon/glass fibre-reinforced composite-based wind turbine blades are more difficult to recycle than other components due to their complexity and heterogeneity. Furthermore, it is hazardous to landfill or incinerate WTBs because these methods could hurt the environment and human health. Thus, recycling WTBs is a practical approach to guarantee wind turbine sustainability for the renewable energy industry. Just 80% to 85% of wind turbine materials can now be recycled. Still, this percentage might rise to 100% with careful attention to recovering all wind turbine materials and adopting circular economy (CE) concepts.

⁴⁰ Ramesh Kumar, K., & Selvaraj, M. (2023). Investigations on the integrated funnel, fan and diffuser augmented unique wind turbine to enhance the wind speed. *Journal of Applied Fluid Mechanics*, 16(3), 575-589. <https://doi.org/10.47176/jafm.16.03.1498>

⁴¹ Muhammed, K. A., Kannan, C. R., & Stalin, B. (2020). Performance analysis of wind turbine blade materials using nanocomposites. *Materials Today: Proceedings*, 33, 4353-4361. <https://doi.org/10.1016/j.matpr.2020.07.578>

⁴² Khalid, M. Y., Arif, Z. U., Hossain, M., & Umer, R. (2023). Recycling of wind turbine blades through modern recycling technologies: A road to zero waste. *Renewable Energy Focus*, 44, 373-389. <https://doi.org/10.1016/j.ref.2023.02.001>.

Additionally, this assessment emphasises WTB composites' difficulties and what lies ahead. It is determined that to increase the viability and effectiveness of wind energy, everyone, researchers, legislators, policymakers, and industry stakeholders, should work consistently and cooperatively.⁴³ Composites with better qualities than regular composites are created by mixing Nano-fluids with traditional reinforced materials. This experimentally based work aims to employ graphene particles in epoxy resin to improve nanocomposites. It also aims to enhance nanocomposites using epoxy resin reinforced with glass fibre and graphene.⁴⁴

3. DISCUSSION ON THE CHALLENGES AND FUTURE TRENDS OF SOLAR-WIND HYBRID ENERGY GENERATING SYSTEMS

According to Abdullahi Agwai, an official with the Nasarawa Ministry of Environment, the authorities are aware of the illicit mining activities in Angwan Kade. However, the official stated that comparable operations take place in several other locations.⁴⁵ The discussion of the challenges and future trends covers wind-on-shore, wind-offshore, Photovoltaic (PV), and Batteries (storage).

i. Wind on shore

In 2013, 361 GW of turbines were installed, with an average size of 1.9 MW. For low-voltage power converters (690 V, for example), the typical LCOE ranges between USD 0.06 and USD 0.12/kWh.⁴⁶

⁴³ Mohamed, M. A., Adel, M., & Abd El-Aziz, A. M. (2023). Recent trends in two-dimensional graphene derivatives-based composites: Review on synthesis, properties and applications. *Journal of Composite Materials*, 57(27), 4327-4364. <https://doi.org/10.1177/00219983231191271>

⁴⁴ Okokpujie, I. P., & Tartibu, L. K. (2023). Aluminium alloy reinforced with agro-waste and eggshell as a viable material for wind turbine blade to annex potential wind energy: a review. *Journal of Composites Science*, 7(4), 161. <https://doi.org/10.3390/jcs7040161>

⁴⁵ Nasir Aytogo, 'SPECIAL REPORT: Misery of Agrarian Nasarawa Community Shows Pitfalls, Potential of Solid Minerals in Nigeria' (2022) Premium Times <https://www.premiumtimesng.com/news/headlines/521574-special-report-misery-of-agrarian-nasarawa-community-shows-pitfalls-potential-of-solid-minerals-in-nigeria.html?tztc=1>

⁴⁶ Blaabjerg, F., Ionel, D. M., Yang, Y., & Wang, H. (2017). Renewable energy systems: technology overview and perspectives. *Renewable Energy Devices and Systems with Simulations in MATLAB® and ANSYS®, 1-16.*

Some energy generation challenges include reliability, grid-code compliance, converters (e.g., 3.3 kV), and wind power converters based on novel semiconductor technologies.

Predictions for 2025 and beyond include a global installation of 700 GW, 50% wind power in Denmark, an increase of 10-20 MW turbines, and improved components and systems.

ii. Wind –Offshore

Wind-off-shore is uncommon in northern Europe. GW installed by 2014; 91%, average size: 3.6 MW in 2013. LCOE of USD 0.14 to USD 0.25/kWh (typical).

Reliability: the interconnection of onshore and offshore wind farms, harmonics, stability, and final High maintenance expenditures.

Global installation of approximately 89 GW, with level reliability and a typical LCOE of USD 0.10 to USD 0.19/kWh.

iii. Photovoltaic (PV)

In 2014, 180 GW of PV inverters with wide band-gap semiconductors were commercialised, resulting in a mean LCOE of USD 0.08 to USD 0.36/kWh.⁴⁷ Address reliability difficulties with medium voltage PV systems, utilise energy storage and integrate with the grid.

The prediction analysis, including high-voltage PV systems, will last 20-30 years. PV inverters with an LCOE of USD 0.06 to USD 0.15/kWh (typical) and micro-inverters

iv. Batteries (storage)

Achieving 75-95% efficiency is cost-effective for off-grid and remote applications. Off-grid storage costs between \$300 and \$3500 per kilowatt.

Improve reliability, use innovative materials to increase energy density, and use battery management systems.

They are improving reliability and density of energy. On-grid uses are expanding, with new systems costing USD 1000 per kW.

⁴⁷ Blaabjerg, F., Chen, M., & Huang, L. (2024). Power electronics in wind generation systems. *Nature Reviews Electrical Engineering*, 1(4), 234-250. <https://doi.org/10.1038/s44287-024-00032-x>

4. ASSESSING THE POLICY OF SOLAR-WIND HYBRID ENERGY GENERATING SYSTEM OPERATIONS IN NIGERIA

Nigeria is in a high solar radiation zone, with an average yearly solar radiation of 2011 kWh/m², as illustrated in Figure 7a. The country's northern region has greater potential, with an average daily solar radiation of 7 kWh/m², making it ideal for large-scale solar-powered thermal or photovoltaic (PV) electricity plants.⁴⁸ By 2030, Nigeria aims to generate more than 30% of its electricity from renewable sources. By 2025, the country plans to increase the overall installed capacity of wind and solar PV.⁴⁹ Figure 7b depicts places with strong wind speeds in Nigeria.

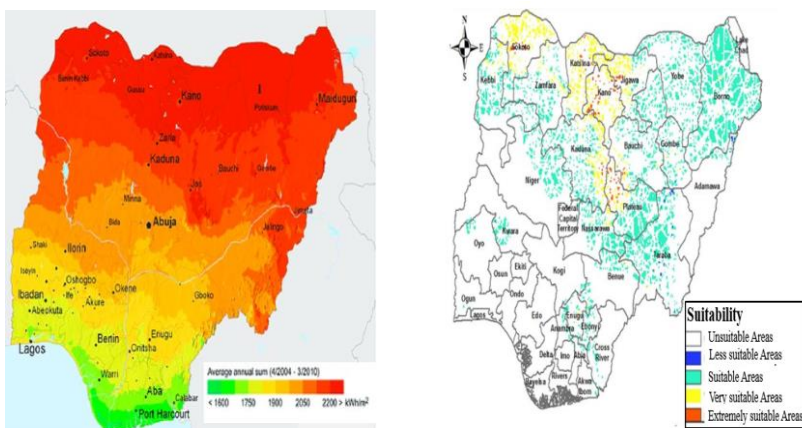

Figure 7: (a) the areas with high solar radiation and (b) the specific location of high wind speed in Nigeria⁵⁰

⁴⁸ Yadav, R. S., & Rathore, V. K. (2024). Advancements and Innovations in Green Hydrogen Technologies. In *Challenges and Opportunities in Green Hydrogen Production* (pp. 211-238). Singapore: Springer Nature Singapore. https://doi.org/10.1007/978-981-97-1339-4_9.

⁴⁹ Cacciuttolo, C., Guardia, X., & Villicaña, E. (2024). Implementation of Renewable Energy from Solar Photovoltaic (PV) Facilities in Peru: A Promising Sustainable Future. *Sustainability*, 16(11), 4388. <https://doi.org/10.3390/su16114388>

⁵⁰ Akpahou, R., Odoi-Yorke, F., Mensah, L. D., Quansah, D. A., & Kemausuor, F. (2024). Strategising towards sustainable energy planning: Modeling the mix of

Knowing that the ability to generate power from solar and Wind energy is more promising and eco-friendly. Nigeria's economy is primarily dependent on the export of oil products and is driven by fossil fuels.⁵¹ The nation has abundant natural energy resources, including wind and solar (primarily in the north and along the coastal line). Nigeria needs an increased electricity supply, enhanced security, and infrastructure dependability.⁵² Additionally, the government is making several efforts to create national policies for renewable energy, which has not been put into reality.^{53,54} Apart from developing a national policy to govern the operations of developing energy from solar and wind, its utilisation needs to be considered. It has been seen that the Nigerian government does not have a source of generating hybrid green energy from solar and wind.^{55,56} Like many developing countries, Nigeria is lagging in incorporating renewable energy into its energy mix. While large-scale hydro contributes 22% of electricity output, renewable energy plays a smaller role.^{57,58} This study will recommend a sustainable way

future generation technologies for 2050 in Benin. *Renewable and Sustainable Energy Transition*, 5, 100079. <https://doi.org/10.1016/j.rset.2024.100079>

- ⁵¹ Olujobi, O. J., Okorie, U. E., Olarinde, E. S., & Aina-Pelemo, A. D. (2023). Legal responses to energy security and sustainability in Nigeria's power sector amidst fossil fuel disruptions and low carbon energy transition. *Heliyon*, 9: <https://doi.org/10.1016/j.heliyon.2023.e17912>.
- ⁵² Adedeji, A. A., Ogunbayo, I., Ajayi, P. I., & Adeniyi, O. (2024). Energy security, governance quality, and economic performance in sub-Saharan Africa. *Next Energy*, 2, 100055. <https://doi.org/10.1016/j.nxener.2023.100055>
- ⁵³ Hassan, Q., Viktor, P., Al-Musawi, T. J., Ali, B. M., Algburi, S., Alzoubi, H. M., ... & Jaszczur, M. (2024). Renewable energy's role in the global energy Transformations. *Renewable Energy Focus*, 48, 100545. <https://doi.org/10.1016/j.ref.2024.100545>
- ⁵⁴ Chattopadhyay, A., Sauer, P. W., & Witmer, A. P. (2024). Can renewable energy work for rural societies? Exploring productive use, institutions, support systems, and trust for solar electricity in the Navajo Nation. *Energy Research & Social Science*, 107, 103342. <https://doi.org/10.1016/j.erss.2023.103342>.
- ⁵⁵ Yang, J. Y., & Dodge, J. (2024). Local energy transitions as process: How contract management problems stymie a city's sustainable transition to renewable energy. *Energy Policy*, 184, 113893. <https://doi.org/10.1016/j.enpol.2023.113893>
- ⁵⁶ Obada, D. O., Muhammad, M., Tajiri, S. B., Kekung, M. O., Abolade, S. A., Akinpelu, S. B., & Akande, A. (2024). A review of renewable energy resources in Nigeria for climate change mitigation. *Case Studies in Chemical and Environmental Engineering*, 9, 100669. <https://doi.org/10.1016/j.cscee.2024.100669>
- ⁵⁷ Idris, W. O., Ibrahim, M. Z., & Alibani, A. (2024). Prospects of solar energy exploration in Nigeria: assessments, economic viability and hybrid system. *International Journal of Energy Economics and Policy*, 14(2), 676-686.

to develop a structural framework for hybrid wind and solar generation. With this suggestion and analysis, the government will be able to produce electricity to meet the needs of the citizens of Nigeria.

4.2 Theoretical Framework for Alternative Analysis to Develop Sources of Energy from Solar and Wind to Provide a Strong Policy for Utilisation

Actions that facilitate the adoption and implementation of a policy decision are included in open policy decision-making. The policy falls into three broad categories: distributive, regulatory, and redistributive.⁵⁹ These policies will contribute to developing and implementing wind and solar energy generation policies. The hybrid must pass these three policy hurdles to be used as a final product in the energy industry. The government and other national stakeholders must make a concerted effort to achieve this. The primary objective of Nigeria's open regulatory policy is to apply solar-wind hybrid energy generating systems as a source of energy generation.⁶⁰ The energy sector's role is to uphold law and order and discourage actions that endanger humankind. Numerous studies have shown that solar-wind hybrid energy is a great possibility.

However, because wind and solar energy are efficient, proper regulation is necessary before using solar-wind hybrid energy as a significant source of the industry's affordable and sustainable energy supply.⁶¹ Thus, structural analysis must be done to design wind and solar farms for energy production systems.⁶² To accomplish this, the government will impose restrictions on

⁵⁸ Ijeoma, M. W., Lewis, C. G., Chen, H., Chukwu, B. N., & Carbajales-Dale, M. (2024). Technical, economic, and environmental feasibility assessment of solar-battery-generator hybrid energy systems: a case study in Nigeria. *Frontiers in Energy Research*, 12, 1397037. <https://doi.org/10.3389/fenrg.2024.1397037>

⁵⁹ Mandel, T., & Pató, Z. (2024). Towards effective implementation of the energy efficiency first principle: a theory-based classification and analysis of policy instruments. *Energy Research & Social Science*, 115, 103613. <https://doi.org/10.1016/j.erss.2024.103613>.

⁶⁰ Olszowski, R. (2024). Opening Policymaking. In *Collective Intelligence in Open Policymaking* (pp. 1-62). Cham: Springer Nature Switzerland. https://doi.org/10.1007/978-3-031-58191-5_1.

⁶¹ Ahmed, M. M. R., Mirsaedi, S., Koondhar, M. A., Karami, N., Tag-Eldin, E. M., Ghamry, N. A., ... & Sharaf, A. M. (2024). Mitigating Uncertainty Problems of Renewable Energy Resources Through Efficient Integration of Hybrid Solar PV/Wind Systems Into Power Networks. *IEEE Access*, 12, 30311-30328. DOI: 10.1109/ACCESS.2024.3370163

⁶² Islam, M. A., Ali, M. N., Al Mamun, A., Hossain, M. S., Maruf, M. H., & Shihavuddin, A. S. M. (2024). Optimising energy solutions: A techno-economic

individuals, collectives, or commercial entities that misuse energy in structural applications that impact the social and political order.⁶³ Protecting the country's economic activity is another distinctive objective for developing solar and Wind energy regulations.⁶⁴ However, industrial enterprises must be prohibited from harvesting improper solar and wind energy, which will hurt the nation's economic development.⁶⁵ Additionally, this regulatory strategy will contribute to the protection of the workplace.

In Nigeria's energy business sector, distributive policy about producing and managing solar and wind energy is essential. The populace must share the benefits of solar and Wind energy generation.⁶⁶ This distributive strategy will encourage a significant investment in the energy needed to create homes, bridges, and roads. Policy formulation is the problem behind the improvement of poor solar and wind utilisation in the energy industry. The energy industry's use of solar and Wind power for energy generation is hampered by decision-makers' ignorance of this issue. Citizens will be encouraged to engage in large-scale solar wind energy farming and the transformation of energy into a variety supply and use for the production of end products by the equalisation of policy for energy implementation in the energy sector to boost the state or local government's ability to generate

analysis of solar-wind hybrid power generation in the coastal regions of Bangladesh. *Energy Conversion and Management*: X, 22, 100605. <https://doi.org/10.1016/j.ecmx.2024.100605>.

- ⁶³ Nassar, Y. F., El-Khozondar, H. J., Alatrash, A. A., Ahmed, B. A., Elzer, R. S., Ahmed, A. A., ... & Khaleel, M. M. (2024). Assessing the viability of solar and Wind energy technologies in semi-arid and arid regions: a case study of Libya's climatic conditions. *Applied solar energy*, 60(1), 149-170. <https://doi.org/10.3103/S0003701X24600218>.
- ⁶⁴ Ofélia de Queiroz, F. A., Morte, I. B. B., Borges, C. L., Morgado, C. R., & de Medeiros, J. L. (2024). Beyond clean and affordable transition pathways: A review of issues and strategies to sustainable energy supply. *International Journal of Electrical Power & Energy Systems*, 155, 109544. <https://doi.org/10.1016/j.ijepes.2023.109544>.
- ⁶⁵ Xiao, Y., Zou, C., Dong, M., Chi, H., Yan, Y., & Jiang, S. (2024). Feasibility study: Economic and technical analysis of optimal configuration and operation of a hybrid CSP/PV/wind power cogeneration system with energy storage. *Renewable Energy*, 225, 120273. <https://doi.org/10.1016/j.renene.2024.120273>.
- ⁶⁶ Joel, O. T., & Oguanobi, V. U. (2024). Geotechnical assessments for renewable energy infrastructure: ensuring stability in Wind and solar projects. *Engineering Science & Technology Journal*, 5(5), 1588-1605. <https://doi.org/10.51594/estj.v5i5.1110>

revenue.⁶⁷ As this will significantly accelerate economic development.⁶⁸ Since they know that solar and wind can be a source of income, public, private, and individual businesses will recognise the chance to participate in the cultivation and processing of hybrid energy generation via solar and wind.⁶⁹ This study suggested that the benchmarking process is introduced to develop a formidable structure for energy generation via solar and wind with a sustainable operation policy.

4.2 Theoretical Framework for Utilization of Benchmarking for Sustainable Policy Development for Hybrid Power Generations via Wind and Solar

The Nigerian government needs to use specific methods to investigate the process of wind and solar farming and calculate the proportion of power generated in various phases.⁷⁰ The authors advocate benchmarking analysis methodologies for building a firm energy generation strategy using an environmentally benign procedure based on wind speed and sun radiation. Hybrid Energy Benchmarking compares the performance of existing energy sources, such as countries that rely heavily on solar energy for power generation.⁷¹ Wind and solar energy generation contributes to potential economic savings. A benchmarking study is an essential approach for establishing policies, laws, and goals for how Nigeria's energy sector might develop alternate forms of energy generation other than fossil fuels.⁷² The

⁶⁷ Zakir, M. N., Abasin, A. R., Irshad, A. S., Elias, S., Yona, A., & Senjyu, T. (2024). Practical Wind Turbine Selection: A Multicriterion Decision Analysis for Sustainable Energy Infrastructure. *Practice Periodical on Structural Design and Construction*, 29(3), 04024028. <https://doi.org/10.1061/PPSCFX.SCENG-1508>.

⁶⁸ Ugwu, M. C., Adewusi, A. O., & Nwokolo, N. E. (2024). The Role Of Public-Private Partnerships In Building Clean Energy Infrastructure In The United States And Nigeria. *International Journal of Management & Entrepreneurship Research*, 6(4), 1049-1068. <https://doi.org/10.51594/ijmer.v6i4.984>.

⁶⁹ Bouraima, M. B., Ayyildiz, E., Badi, I., Murat, M., Es, H. A., & Pamucar, D. (2024). A decision support system for assessing the barriers and policies for wind energy deployment. *Renewable and sustainable energy reviews*, 200, 114571. <https://doi.org/10.1016/j.rser.2024.114571>.

⁷⁰ Okokpuije, I. P., Akinlabi, E. T., & Fayomi, O. O. (2020). Assessing the policy issues relating to the use of bamboo in the construction industry in Nigeria. *Heliyon*, 6(5). <https://doi.org/10.1016/j.heliyon.2020.e04042>.

⁷¹ Damo, U. M., Ahmed, T., Ozoegwu, C. G., Sambo, A. S., Aktas, A., Akca, H., ... & Bahaj, A. S. (2024). Solar PV potential in Africa for three generational time scales: present, near future and far future. *Solar Energy*, 275, 112638. <https://doi.org/10.1016/j.solener.2024.112638>

⁷² Olayungbo, D. O., Faiyetole, A. A., & Olayungbo, A. A. (2024). Investigating the role of subsistence renewables in alleviating power poverty within Nigeria's

energy benchmarking method is appropriate for indicating areas where high wind and solar radiation developments should receive particular focus.

In some cases, temporal benchmarking might reveal the need for policymaking in the energy production process to its current level using sustainable sources.⁷³ The government can conduct the benchmarking process in two ways: top-down and bottom-up.⁷⁴ The approach from the top down is an easy way of studying the yearly report on the energy used as a finished product and the manufacturing data of the energy from the two primary sources.⁷⁵ Wind and solar power, or the bottom-up method, assesses the energy extraction stage audit and the production data obtained from the wind speed in the surroundings.⁷⁶ These two procedures are critical techniques that necessitate a high level of commitment from decision-makers, energy operators, and end consumers.⁷⁷ However, the benchmarking process consists primarily of five steps: planning, analysis of the data, incorporation of the results, executing the findings, assessments or evaluations of the benchmarking procedure's performance, and establishing a policy for the delivery of energy generation for Nigeria's energy sectors, as shown in Figure 8.

energy-mix strategy. *Sustainable Energy Research*, 11(1), 11. <https://doi.org/10.1186/s40807-024-00105-3>

- ⁷³ Shari, B. E., Moumouni, Y., Ohunakin, O. S., Blechinger, P., Madougou, S., & Rabani, A. (2024). Exploring the role of green hydrogen for distributed energy access planning towards net-zero emissions in Nigeria. *Sustainable Energy Research*, 11(1), 16. <https://doi.org/10.1186/s40807-024-00107-1>.
- ⁷⁴ Okokpujie, I. P., Okokpujie, K., Omidiora, O., Oyewole, H. O., Ikumapayi, O. M., & Emuowhocere, T. O. (2022). Benchmarking and Multi-Criteria Decision Analysis Towards Developing a Sustainable Policy of Just in Time Production of Biogas in Nigeria. *International Journal of Sustainable Development & Planning*, 17(2). <https://doi.org/10.18280/ijstdp.170208>.
- ⁷⁵ Bracken, C., Voisin, N., Burleyson, C. D., Campbell, A. M., Hou, Z. J., & Broman, D. (2024). Standardised benchmark of historical compound wind and solar energy droughts across the Continental United States. *Renewable Energy*, 220, 119550. <https://doi.org/10.1016/j.renene.2023.119550>.
- ⁷⁶ Alghanem, H., & Buckley, A. (2024). Global Benchmarking and Modelling of Installed Solar Photovoltaic Capacity by Country. *Energies*, 17(8), 1812. <https://doi.org/10.3390/en17081812>.
- ⁷⁷ Okokpujie, I. P., Tartibu, L. K., & Omietimi, B. H. (2023). Improving the Maintainability and Reliability in Nigerian Industry 4.0: Its Challenges and the Way Forward from the Manufacturing Sector. *International Journal of Sustainable Development & Planning*, 18(8). <https://doi.org/10.18280/ijstdp.180820>.

These five steps are briefly described to guide stakeholders/decision makers through the process of building an energy policy for renewable energy production via wind and solar, utilising the benchmarking policy framework as follows:

i. Step One

The planning procedure should involve a committee of five or seven members, with a sub-group to identify places in Nigeria with high solar and wind speeds.

Utilise their workers to maintain high inventory levels at the specified location.

Use a common technique to collect data from each state as intended.

Determine the cost of developing a sustainable hybrid solar and Wind energy farm and the expected output.

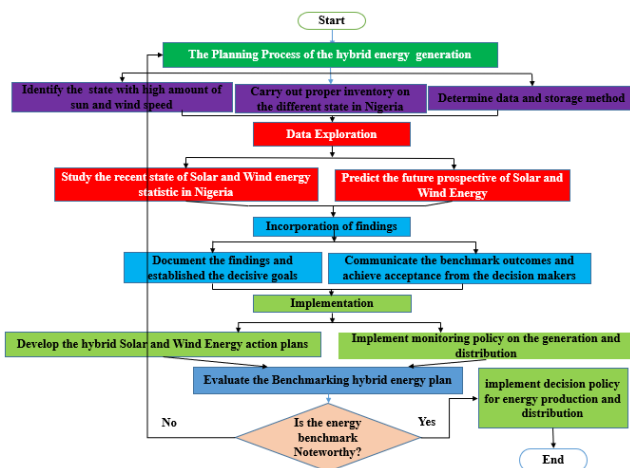

Figure 8: The structural theoretical framework for the benchmarking policy procedure for the hybrid generation of energy via solar and wind (Authors design)

This approach should take three to six months for the committee to compile a comprehensive record of the sun's most plentiful state for solar radiation and

wind speed. As a result, the committee is in charge of establishing a dynamic data collection method that would allow for proper data analysis.⁷⁸

ii. Step Two

Following the successful data collection, the data analyst will undertake research to assess the present statistical situation of sun radiation and wind speed in Nigeria. The data analyst is in charge of identifying which strategy will yield the best and most secure results in terms of energy generation.⁷⁹

At this point, the data analyst will create a model to forecast the future life duration of energy generation in Nigeria using sun and wind speed. This prediction model will help the country comprehend the practical aspects of building a power supply for its citizens using hybrid wind and solar energy and the implementation process. The committee should ensure that correct data is obtained since it would substantially impact the integration of solar radiation and wind speed findings for Nigeria's energy systems.

iii. Step Three

This section has two significant levels, which are:

Documenting all states in Nigeria with high solar radiation and wind speed, as well as local materials suitable for renewable energy generation and functional purposes.

The committee must explain benchmarking findings and operational objectives to get acceptance from decision-makers.

At this point, the committee, stakeholders, and decision-makers must integrate their ideas, visions, and goals to develop good and reasonable strategies to implement the findings.

iv. Step Four

The stage of execution is critical, as there is a real need to design a solar and wind energy generation action plan as well as an executing monitoring strategy based on the proposed action plan. This action plan should include step-by-step procedures for generating and distributing energy produced by

⁷⁸ Dodd, J. R., Smithwick, J., Call, S., & Kasana, D. (2023). The current state of benchmarking use and networks in facilities management. *Benchmarking: An International Journal*, 30(7), 2377-2407.

⁷⁹ Willetts, M., & Atkins, A. S. (2023). Performance measurement is used to evaluate the implementation of big data analytics in SMEs using benchmarking and the balanced scorecard approach. *Journal of Data, Information and Management*, 5(1), 55-69. <https://doi.org/10.1007/s42488-023-00088-8>.

the hybrid solar and wind turbine, as well as a breakdown structure of how the system will be able to fulfill the specific goal. Furthermore, if possible, the committee formed should be able to choose a specific location for the manufacturing or process industry for hybrid energy generation. To enable the optimal grid supply of generated energy, storage capacity, and distribution to customers.

v. *Step Five*

The committee, stakeholders, and decision-makers must implement an appropriate process evaluation framework. However, the evaluation results will influence the decision based on energy analysis benchmarking. This is a vital moment in which the nation's decision-makers must understand the importance of renewable energy generation to economic progress.⁸⁰ Furthermore, when this committee communicates this knowledge to decision-makers, lawmakers, and stakeholders, they can create and implement an excellent policy to assist Nigeria in operating and regulating hybrid energy generation through solar and Wind energy processes for long-term electricity supply.

5. CONCLUSION AND RECOMMENDATIONS

This study has successfully reviewed the literature on integrating and implementing wind and solar energy into the national grid as a viable source of energy generation in Nigeria. It has been seen that there is no standing policy for harnessing solar radiation and wind energy regarding energy generation in Nigeria. Nigeria has not been able to integrate the renewable energy generation process as a significant source of energy generation in order to eliminate the epileptic supply of electricity in Nigeria. Also, it can be seen that both the onshore and offshore have some concerns with electricity generation, which are reliability, grid-code compliance, converters (3.3 kV), and wind power converters based on novel semiconductor technologies—interconnection between onshore and offshore wind farms Harmonic and stability difficulties, final high maintenance expenditures.

⁸⁰ Hunaiti, Z., & Huneiti, Z. A. (2024, May). Prospects and Obstacles Associated with Community Solar and Wind Farms in Jordan's Suburban Areas. In *Solar* (Vol. 4, No. 2, pp. 307-328). MDPI. <https://doi.org/10.3390/solar4020014>.

Furthermore, in Photovoltaic (PV) Current Status: 180 GW was built in 2014, PV inverters with wide band-gap semiconductors were commercialised, and the LCOE ranged from USD 0.08 to USD 0.36/kWh (typical). The challenge of solar energy is the medium voltage PV systems, energy storage for PV systems, and Grid integration to meet more demands. This study has proven a profound need to plan a firm policy on the regulations of hybrid generation of electricity in the energy sector in Nigeria. Moreover, it provides valuable evidence for the stakeholders to realise their role in Nigeria's policy development and solar and wind integration operation implementation. Therefore, this study suggests a reliable method that can be used to develop a strong policy for the production process of energy via solar and Wind energy processes and for the proper distribution processes via the Benchmarking method.